

HDS HYDRAULIC DREDGING SYSTEMS

HYDRAULIC 90 KW / 120 HP DISCHARGE 8 INCH

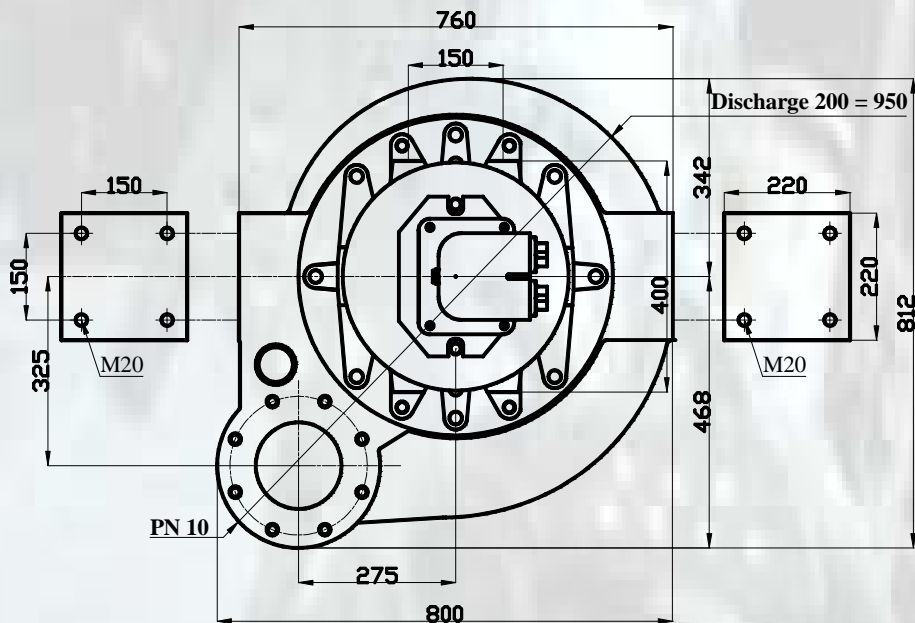
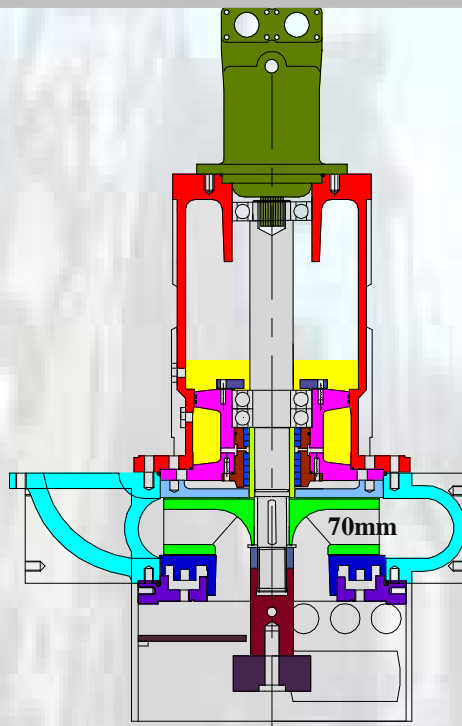
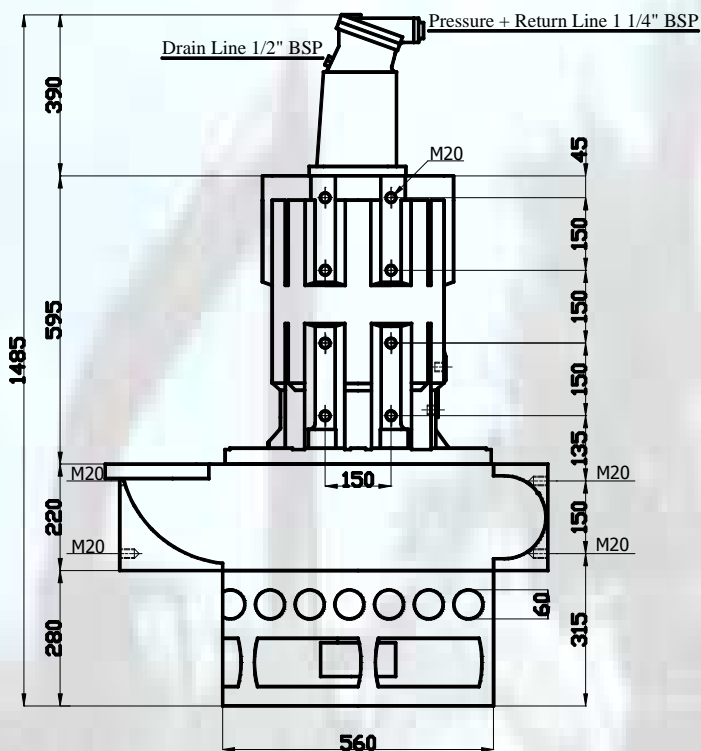

Specifications:

Hydraulic Driven 90 KW 120 HP 980 up to 1275 RPM
 1420 RPM Intermittent
 Oil Supply at 980 RPM = 174 L/ MIN
 Oil Supply at 1275 RPM = 226 L/MIN
 Oil Supply at 1420 RPM = 252 L/Min
 Oil Pressure at 980RPM 120 BAR
 Oil Pressure at 1275 RPM 210 BAR
 Oil Pressure at 1420 RPM 280 BAR
 Max Pressure 350 BAR
 TORQUE= 2, 56 Nm/BAR

WEAR PARTS CHROM CASTING
 SHAFT 42 CRMo4-DIN 7225-SAE 4140
 EXCAVATOR MOUNTING PADS
 STRAINER 60 MM

DISCHARGE PIPE 8 INCH 200mm

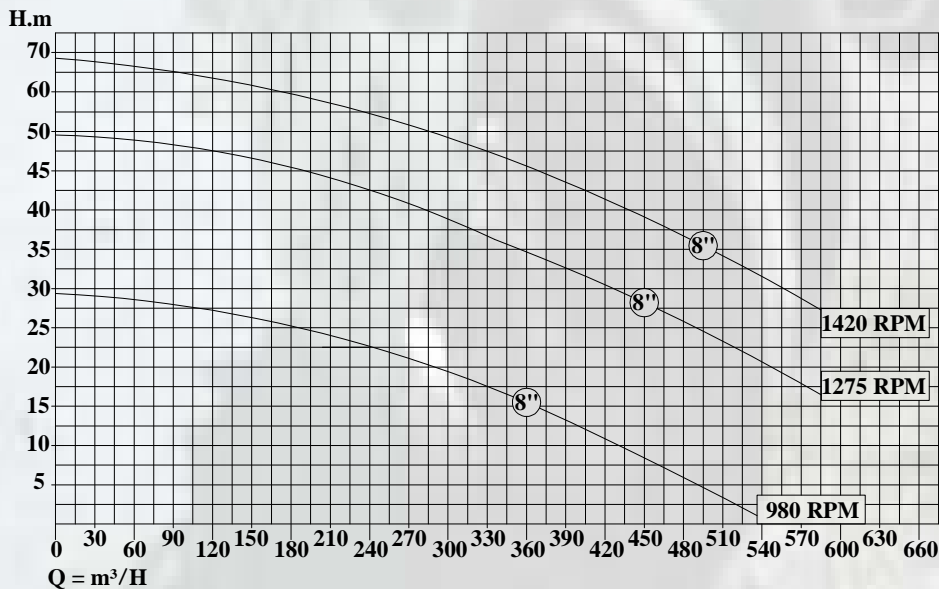

| | |
|----------|----------|
| 1000RPM | 1275RPM |
| 370 M3/H | 450 M3/H |
| 16 M | 27 M |

1420RPM
 500 M3/H
 35 M
 Intermittent
 High Wear

IMPELLER WIDTH 70mm

WEIGHT 766 KG

WEBSITE : www.hdsbelgium.com

E - mail : hds@hdsbelgium.com