

HDS HYDRAULIC DREDGING SYSTEMS

HYDRAULIC 60 KW / 80 HP DISCHARGE 6 OR 8 INCH

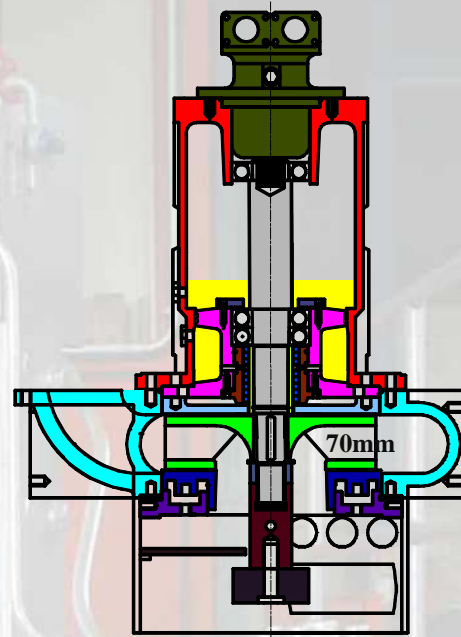
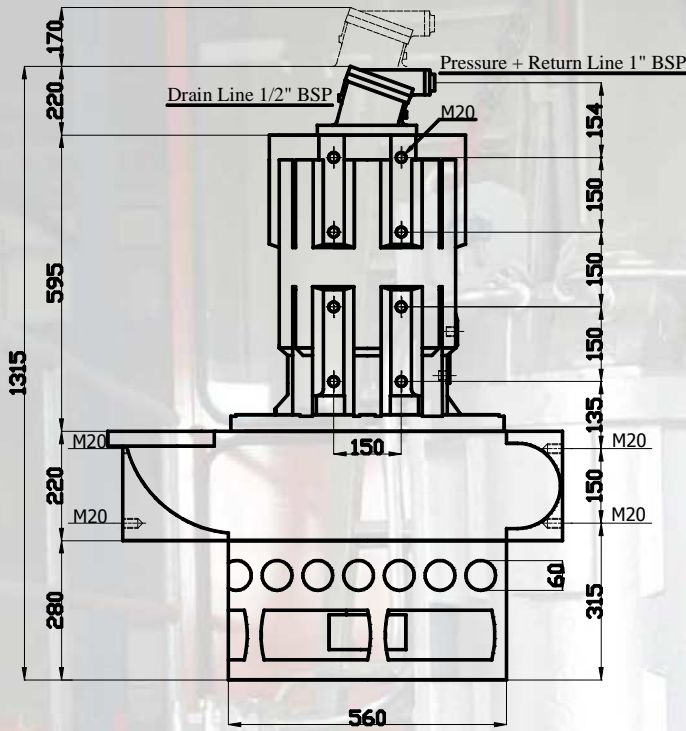

Specifications:

Hydraulic Driven 60 KW 80 HP 1000 up to 1150 RPM
 Oil Supply at 1000 RPM = 120 L / MIN
 Oil Supply at 1150 RPM = 138 L / MIN
 Oil Pressure at 1000 RPM 220 BAR
 Oil Pressure at 1150 RPM 280 BAR
 Max Pressure 350 BAR TORQUE= 1, 7 Nm/BAR

WEAR PARTS CHROM CASTING
 SHAFT 42 CRMo4-DIN 7225-SAE 4140
 STRAINER 60 MM
 EXCAVATOR MOUNTING PADS
 IMPELLER WIDTH 70mm

| | | |
|--------------------------|-----------|----------|
| DISCHARGE PIPE | 6 INCH | 8 INCH |
| | 150 MM | 200 MM |
| CAPACITY - 1000RPM HEAD | 200 M3/ H | 370 M3/H |
| | 24 M | 16 M |
| CAPACITY - 1150 RPM HEAD | 240 M3/H | 400 M3/H |
| | 34 M | 24 M |

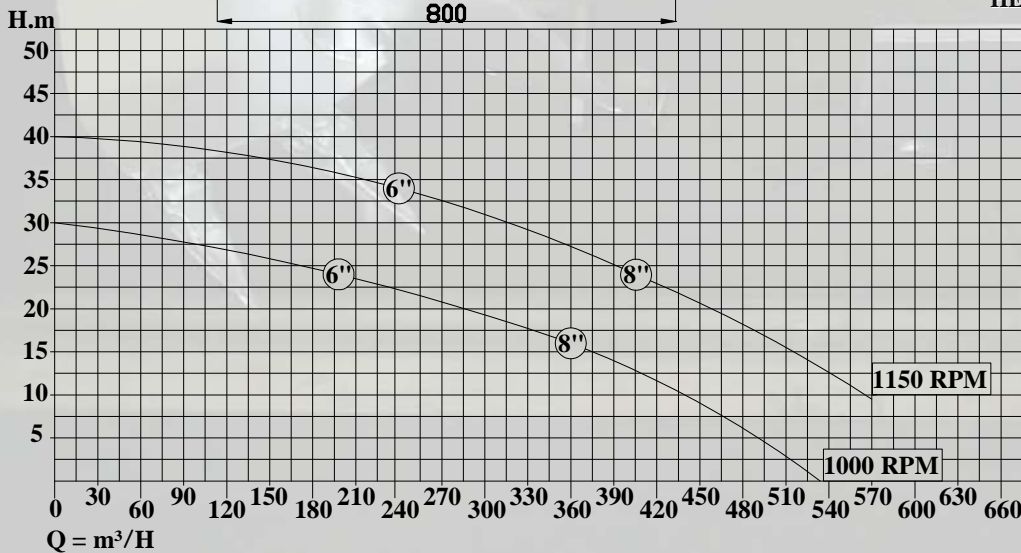
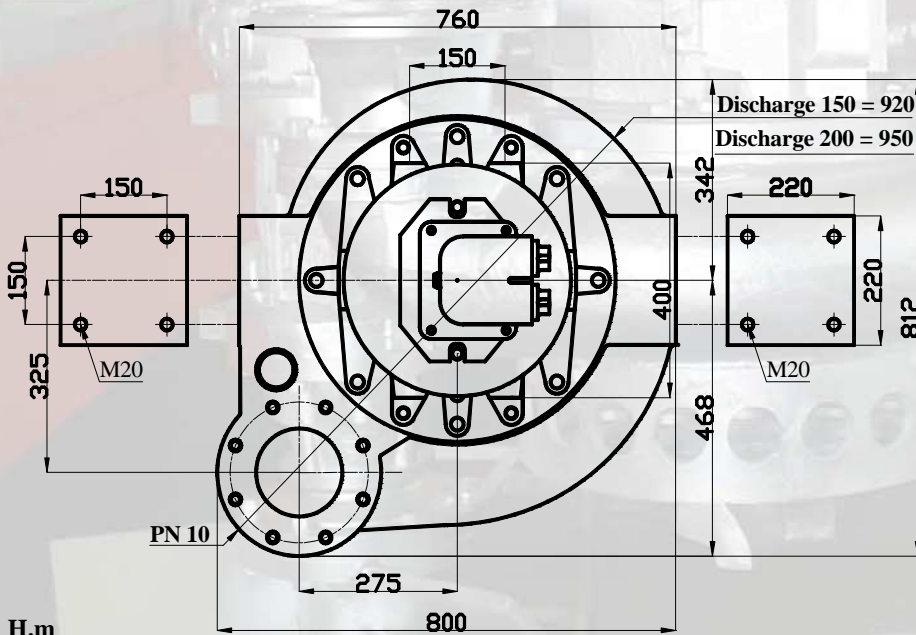

IMPELLER WIDTH 70mm

WEIGHT 750 KG

WEBSITE : www.hdsbelgium.com

E - mail : hds@hdsbelgium.com