

# HDS HYDRAULIC DREDGING SYSTEMS

HYDRAULIC 185KW/250HP AND 220KW/300HP DISCHARGE 12 INCH

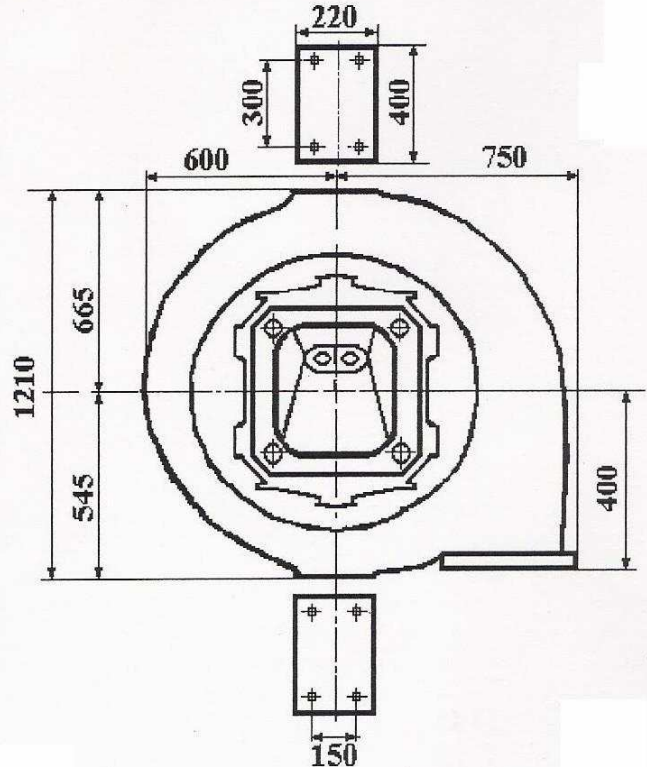
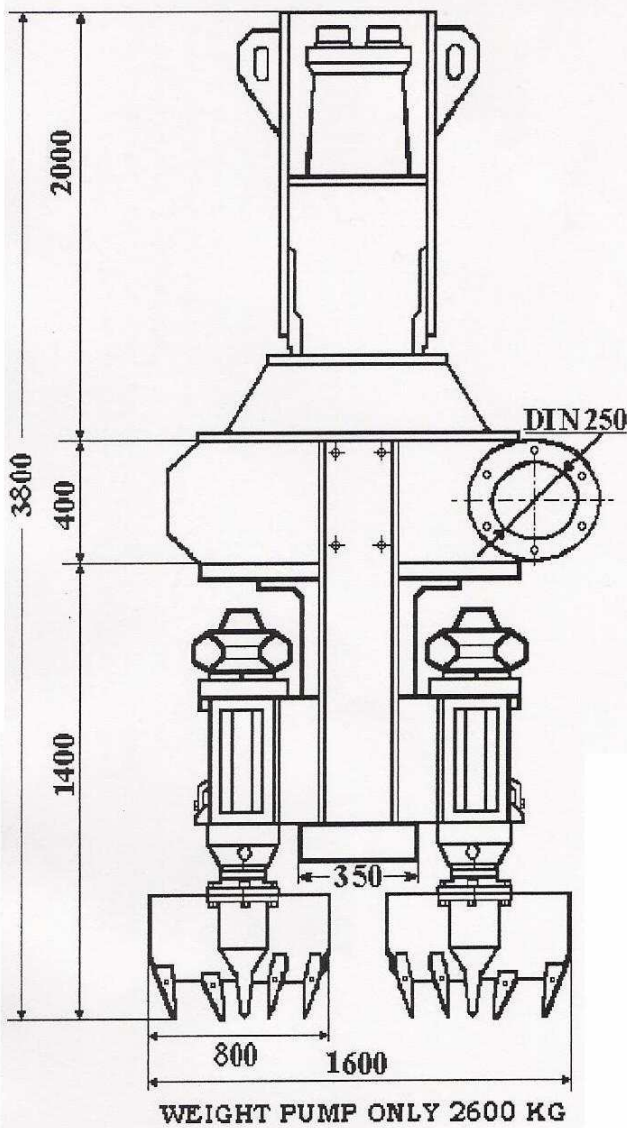

HYDRAULIC DRIVEN 220 KW 300 HP 12 INCH  
 SPEED RANGE 735 / 775 RPM  
 OIL SUPPLY AT 775 RPM 450 L/MIN  
 OIL PRESSURE 300 BAR  
 TORQUE Nm 7,95 / BAR

CAPACITY 1000 M3 / H  
 HEAD 36 M

WEAR PARTS CHROM CASTING  
 SHAFT 42Cr Mo4 DIN 7225-SAE 4140  
 STRAINER 120 MM  
 EXCAVATOR MOUNTING PADS  
 SPECIFICATIONS EXCAVATORS  
 SEE EXCAVATOR LEAFLET

